

# ISOLATION OF BUILDINGS FROM RAILWAY VIBRATION: A CASE STUDY

Dave Anderson

Arup Acoustics, 477 Kent Street, Sydney, 2000

The Bridgewater Hall in Manchester, UK, forms the new home for the Hallé orchestra and a major international venue for symphonic and classical music. The hall comprises a 2400 seat auditorium together with orchestral accommodation and backstage facilities. This paper presents the design of the vibration isolation system used to prevent excessive groundborne noise from the adjacent railway. Predictions and measurements are compared, showing reasonable agreement of overall results but with significant differences in source levels, propagation losses and isolation insertion loss.

## 1 INTRODUCTION

The concert hall site is approximately 30m from the “Metrolink” light rail transit system in Manchester, UK (see Figure 1). Both the hall and the railway are founded on sandstone bedrock. The risk of disturbance due to groundborne railway vibration was identified at the outset of the concert hall design in 1989 and vibration isolation was incorporated in the building to mitigate the problem.

The Metrolink railway is a new system and was not operating at the time of the building design. The vibration isolation design was therefore carried out on the basis of predicted railway vibration levels, as described in Section 2. The detailed considerations taken into account during the isolation design are described in Section 3 while the results of vibration and noise measurements carried out on the site during the life of the project are presented in Section 4.

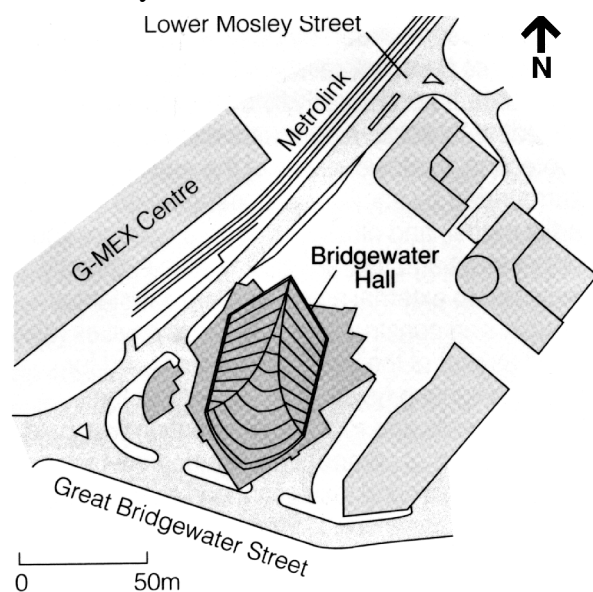

**Figure 1:** Site Plan

## 2 PREDICTED VIBRATION AND NOISE LEVELS

The railway vibration levels at 10m from the track were estimated based on results from similar light rail transit (LRT) systems in Europe, including the Docklands light railway in London, UK and the LRT in Nantes, France. Vibration levels at the concert hall location (30m from the track) were predicted using estimated propagation losses in the bedrock. The estimated losses were derived from relevant literature<sup>1,2</sup>, supplemented by the results of on-site propagation tests using a tripod borehole construction rig as the source, and vibration transducers located in boreholes at bedrock level (10m and 30m from the source) as the receivers.

Noise levels in the auditorium were predicted by considering the acoustic power,  $W$ , radiated by a surface with a mean square normal surface vibration velocity,  $\langle v^2 \rangle$  averaged over time and the surface area, determined by the relation

$$W = \rho c S \sigma \langle v^2 \rangle$$

where  $S$  is the surface area of the vibrating structure and  $\sigma$  is the radiation efficiency. It was assumed that the coupling loss (ie the loss in vibration energy at the interface between the rock and the building foundations) would be negligible and that the vibration response of floor and wall elements of the hall would provide an overall amplification factor between 3 and 5dB. Substituting for the characteristic impedance of air,  $\rho c = 416 \text{ kgm}^{-2}\text{s}^{-1}$ , the vibration velocity level,  $L_v$  with a reference velocity of  $1 \times 10^{-9} \text{ m/s}$ , and solving for the radiated sound power level,  $L_w$ , referenced to  $1 \times 10^{-12} \text{ W}$ , gives

$$L_w = L_v + 10 \log_{10} S + 10 \log_{10} \sigma - 34 .$$

The radiation efficiency ( $\sigma$ ) varies with frequency ( $f$ ) depending on the material properties and construction of the radiating surface, but can generally be assumed to be unity above the panel critical frequency. The predicted noise levels were compared with a recommended train noise limit, which is slightly higher than the PNC15 design goal for continuous noise from the services systems (air conditioning, lighting etc). The results of the predictions are shown in Table 1.

	Octave Band Centre Frequency, Hz		
	31.5	63	125
Predicted vibration velocity level at 10m from the Metrolink railway, dB re $1 \times 10^{-9} \text{ m/s}$	88	95	90
Predicted vibration velocity level at 30m from the Metrolink railway, dB re $1 \times 10^{-9} \text{ m/s}$	80	83	75
Predicted structure-radiated noise level in the auditorium, dB re $20 \mu\text{Pa}$	63	66	57
PNC15 (limit for continuous noise from building services, etc), dB re $20 \mu\text{Pa}$	58	43	35
Recommended train noise limit (TNL), dB re $20 \mu\text{Pa}$	63	50	40
Predicted excess above TNL, dB	0	16	17

**Table 1:** Predicted vibration and noise levels (without building isolation)

### 3 BUILDING ISOLATION DESIGN

It was clear from the predictions (Table 1) that the auditorium would require substantial protection from groundborne railway vibration. Vibration isolation at source (ie at the railway) was strongly recommended but, unfortunately, could not be incorporated cost effectively due to the imminent construction of the railway system. Design options for isolating the building structure were therefore evaluated, with the aim of identifying the system offering the best practical isolation performance.

Although the auditorium is the only acoustically critical space requiring protection from railway vibration, it was decided that the whole building should be isolated, rather than just the hall. Experience from previous structural isolation projects had indicated that internal resilient joints between isolated and non-isolated parts of a building are costly and introduce significant risks of bridging. Figure 2 shows the concept design for the vibration isolation, incorporating resilient bearings below the whole building. The main heating, cooling and ventilation plant is located in a separate building as part of the strategy for controlling noise ingress to the auditorium. The plant tower building is the only part of the complex which is not isolated from the ground. Consequently, all service connections between the plant tower and the concert hall building required resilient connection details such as those shown in Figure 3.

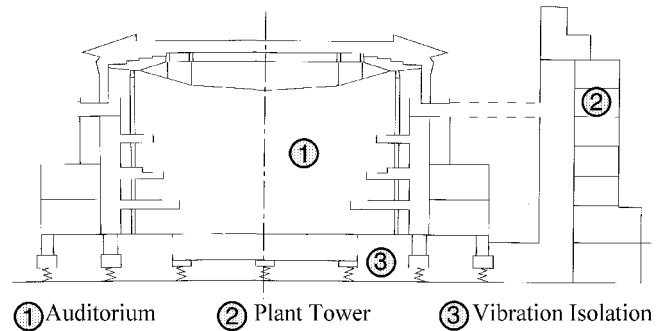

**Figure 2:** Section

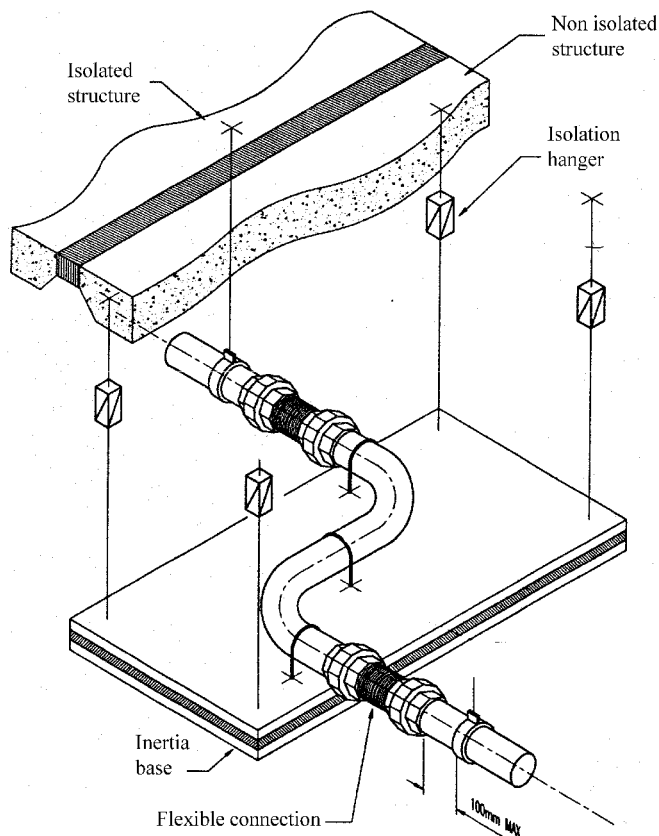

**Figure 3:** Resilient pipe connection

The next step in developing the building isolation design was to determine the appropriate type of resilient bearing. Detailed consideration was given to the two primary alternatives; elastomeric pads (which have been used in many isolated building structures<sup>3</sup>) and helical steel springs (which have been used on a number of more recent projects<sup>4,5</sup>).

There are a number of differences in the dynamic behaviour of elastomeric pads and steel springs. The first difference is the natural frequency ( $f_n$ ) which can be achieved under structural loading conditions. Simple single degree of freedom theory indicates that a lower natural frequency provides better isolation performance (at  $f > \sqrt{2}x f_n$ ). To date, elastomeric pads have typically been used in building isolation systems with natural frequencies in the range of 10 to 15Hz. One or two projects have achieved lower

natural frequencies, in the region of 7Hz<sup>6</sup>, and proposals have been developed for an elastomeric bearing system with a natural frequency of approximately 4Hz (although these have yet to be tested in a building structure). Lower natural frequencies require larger (and therefore more costly) bearing assemblies and result in substantial static deflections under the dead load of the supported building. High deflections can cause problems during the construction phase (due to differential deflections) and are associated with increased incidence of long term creep.

Steel spring systems for building isolation are most cost efficient in the range of 3Hz to 5Hz natural frequency. (Higher natural frequencies require stiffer springs, while lower natural frequencies can compromise spring stability.)

Perhaps the most important difference between elastomeric pads and steel springs lies in the dynamic characteristics of the materials and components. Elastomeric materials have the advantage of solid-type damping<sup>7</sup> which allows the slope of the transmissibility response to follow the ideal 12dB per octave curve above the natural frequency (assuming a single degree of freedom system). Steel spring systems have minimal inherent damping, but are often used in conjunction with viscous damping devices (dashpots) which result in a less desirable 6dB per octave transmissibility slope.

Elastomeric materials exhibit significant non-linear effects. At a given excitation amplitude, the dynamic stiffness of an elastomeric mount increases with frequency. At a given excitation frequency, the dynamic stiffness decreases with increasing displacement amplitude. These effects can be critical in an isolation system designed to protect a sensitive building from groundborne railway vibration because; the excitation frequencies are high (typically 10 to 20 times the natural frequency), and the excitation displacement amplitudes are very small (typically of the order of  $10^{-7}$ m rms displacement).

Both types of isolator also exhibit a number of ‘whole body’ effects, such as wave effects in elastomeric pads and the coil resonance in a spring.

In addition to the practical aspects of isolator dynamic performance, it is, of course, important to note that the dynamic response of the structure departs significantly from the “lumped mass” assumption of simple single degree of freedom theory, further limiting the overall isolation performance which can be achieved<sup>8,9</sup>. In practice, limiting values of isolation performance are typically found to be 15 to 20dB which compares poorly with theoretical performance in excess of 40dB at  $f > 10 \times f_n$ .

It was determined that the best practical isolation performance for this project could be obtained with helical steel springs (without viscous damping), providing a natural frequency of approximately 3.5Hz. The spring units were provided by Gerb Schwingungsisolierungen GmbH (of Essen,

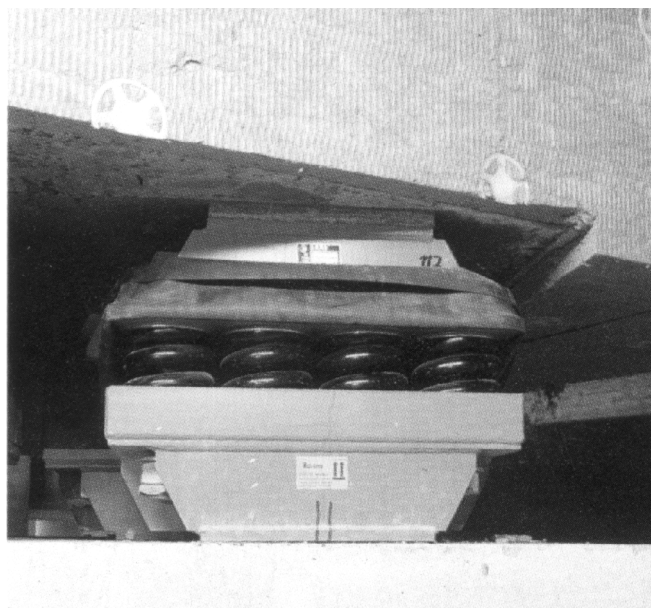

**Figure 4:** Spring unit

Germany) and a typical unit is shown in Figure 4. The spring assemblies are provided with two significant features; pre-compression (typically to 80% of the expected dead load of the structure) to avoid deflection during the early stages of construction of the superstructure, and embedment of the spring coils in a ‘bath’ of viscous liquid, to damp the coil resonance effect.

Even with the spring isolation system, noise predictions suggested that train noise levels would still be likely to exceed the recommended limit within the auditorium. A program of measurements was therefore conducted during the remainder of the project to monitor any variations from predicted effects. The results are discussed in Section 4.

#### 4 SITE MEASUREMENT RESULTS

The Metrolink railway began operation in June 1992. The first measurements of groundborne railway vibration were carried out on the site shortly afterwards, even though the construction of the concert hall building had not yet begun. The measurements were achieved by excavating to bedrock level at the future concert hall location and attaching transducers to the rock via a concrete pad foundation. The results are shown in Table 2, and are compared with the earlier predictions.

Distance from track	Description	Octave Band Centre Frequency, Hz		
		31.5	63	125
10m	Measurement	96	95	78
	Prediction	88	95	90
	Difference, dB	8	0	-12
30m	Measurement	81	75	44
	Prediction	80	83	75
	Difference, dB	1	-8	-31

**Table 2:** Measured source vibration levels, compared with predictions, dB re  $1 \times 10^{-9} \text{m/s}$

Given the (inevitably) wide tolerances on the estimates, the predicted vibration levels and propagation effects are in reasonable agreement with the measurements at 31.5Hz and 63Hz. At 125Hz, however, the source levels were overestimated by more than 10dB and the losses in the ground were underestimated by nearly 20dB. The reduced vibration output at 125Hz compared with the results achieved by similar LRT systems is considered to be due to the resilience of the polymer embedment used for the rail. The ground propagation effects may be due to local variations in the jointing of the bedrock. The overall implication of the measured source vibration levels was that less isolation performance was required of the spring system than had been previously predicted. The required isolation performance was therefore more likely to be achieved and the project could proceed with a less severe risk of unacceptable train noise levels.

The next measurements carried out on site were conducted in 1994 after the construction of the concrete pad footings and sub-structure columns. The results showed that most of the site was

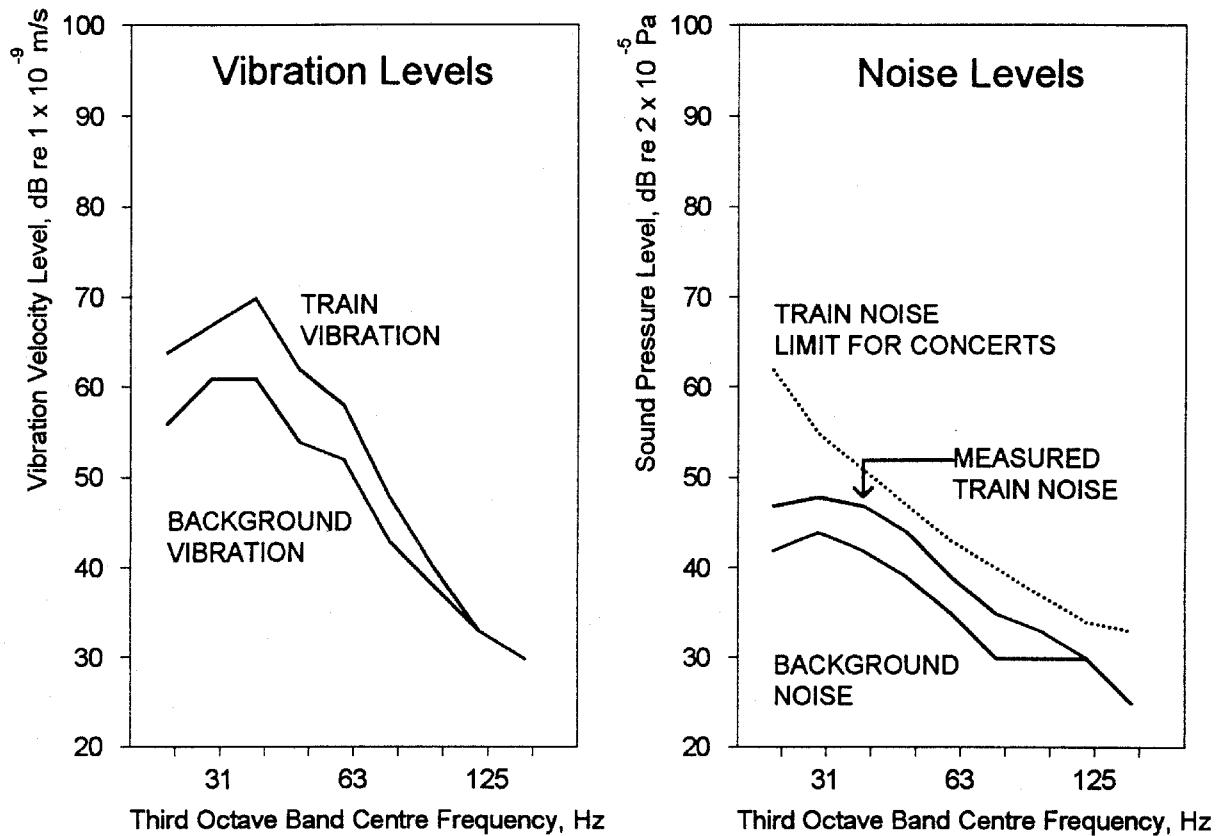

**Figure 5:** Measured vibration and noise levels in the stalls of the auditorium

exposed to vibration levels similar to those measured on the test foundation in 1992. However, a small number of foundation columns exhibited vibration levels 10 to 15dB higher in the 63Hz octave than those on the test foundation. The reason for this was not clear, but several of the affected columns were located adjacent to the alignment of a disused canal which had been buried during a previous use of the site. It was suspected that the buried canal walls formed a structural link between the railway and part of the site. The walls were therefore excavated and moderate reduction in vibration (5 to 7dB) was achieved on the affected foundations.

The final phase of measurements took place when the concert hall building neared completion in 1996. Vibration measurements were carried out above and below the spring units, in the auditorium (at stalls and gallery levels) and in the roof structure. Simultaneous noise level measurements were made in the hall. The results for the stalls are shown in Figure 5. They indicate that train vibration and structure-radiated noise levels could be detected above background levels in the frequency range spanning the 25Hz to 100Hz third octave bands. The noise levels were close to (but within) the design target, indicating that a successful outcome was achieved.

Vibration measurements below spring level showed similar results to the earlier survey carried out before the construction of the superstructure, although in certain frequency bands the vibration levels had decreased by up to 3dB. This reduction may be the result of the imposed structural load.

As expected, vibration levels above the springs were significantly lower than those below, due to the isolation performance of the springs. It must be noted, however, that the difference between

vibration levels above and below the springs can not be considered to be indicative of the spring performance. This is because the vibration measurements represent the forced response of parts of a very complex structure, each part of which exhibits its own response behaviour. Typical results from vibration measurements carried out above and below spring units are given in Table 3.

Vibration and noise levels at the gallery level of the hall were very similar to those at stalls level, suggesting that vibration energy was spread evenly throughout the seating area of the auditorium. It was not possible to detect any vibration above background levels within the roof structure above the auditorium.

Location	Third octave Band Centre Frequency, Hz					
	25	31.5	40	50	63	80
Below spring units	66	74	79	80	80	63
Above spring units	58	58	55	58	57	50
Difference, dB	8	16	24	22	23	13

**Table 3:** Measured vibration levels above and below spring units, dB re  $1 \times 10^{-9}$  m/s

An alternative to comparing vibration levels above and below springs as a measure of installed isolation performance is to compare the predicted and measured transfer functions between the foundation columns and the auditorium. This comparison is given in Table 4.

	Third octave Band Centre Frequency, Hz					
	25	31.5	40	50	63	80
Predicted vibration velocity level at foundations, dB re $1 \times 10^{-9}$ m/s	70	75	78	78	80	75
Predicted structure-radiated noise level in auditorium (without spring isolation), dB re 20 $\mu$ Pa	53	58	61	61	63	58
Difference (= predicted transfer function), dB	17	17	17	17	17	17
Measured vibration velocity level at foundations, dB re $1 \times 10^{-9}$ m/s	66	74	79	75	75	63
Measured structure-radiated noise level in auditorium (with spring isolation), dB re 20 $\mu$ Pa	48	49	48	44	39	35
Difference (= measured transfer function), dB	18	25	31	31	36	28
Difference between measured transfer function and predicted transfer function (= apparent isolation performance)	1	8	14	14	19	11

**Table 4:** Predicted and measured transfer functions between the foundations and the auditorium

The analysis shown in Table 4 suggests slightly lower isolation than the simple comparison of vibration levels above and below the springs. More importantly, both indicators of isolation performance confirm that the results achieved are substantially less than the performance which would be expected from a single degree of freedom system.

## 5 DISCUSSION AND CONCLUSIONS

The vibration isolation system for the new Bridgewater Hall in Manchester has successfully protected the auditorium from disturbance due to groundborne noise from the Metrolink railway.

The measurements carried out before and during the construction of the hall provide useful insight into the generation and propagation of railway vibration and noise. Many of the results confirm the predicted effects. However, the measurements also highlighted a number of effects which had not been predicted, the most significant being:

- that railway vibration levels in the 125Hz octave band were less than predicted due to the resilient rail embedment,
- that attenuation of vibration with propagation in the ground was greater than predicted in the 125Hz octave band at many parts of the site, and
- that attenuation of vibration with propagation in the ground was much less than predicted in the 63Hz octave band at parts of the site near to a buried canal wall.

At the end of a building isolation project it is desirable to determine the achieved isolation performance of the chosen isolation system. Unfortunately the isolation performance of a complex building system can not be measured directly. Instead, it must be estimated from comparison of measured and predicted vibration response of accessible parts of the structure. This type of comparison has been carried out on this projects and confirms that the isolation performance achieved is significantly less than that which would be expected from single degree of freedom theory (approximately 20dB in this case).

## REFERENCES

1. NELSON, P.M. (ED.) (1987) "Transportation Noise Reference Book", *Butterworths, Cambridge, UK*
2. SAURENMAN, H.J., NELSON, J.T., WILSON, P.W. (1982) "Handbook of Urban Rail Noise and Vibration Control", *U.S. Department of Transportation, Washington, U.S.A.*
3. COWELL, J.R. (1993) "Some recent examples of building isolation from railway vibration and structureborne noise", *TRB Committee U.S.A. Convention, Berkeley, California, U.S.A.*
4. MANNING, C.J. (1991) "Noise and vibration from the Ludgate Railway works", *Proceedings of the Institute of Acoustics*, 13 (5).
5. COMMINS, D., LENEUTRE, C., VANPEPERSTRAETE, S. (1990) "Vibration isolation of trains in a French arts complex", *Proceedings of the Institute of Acoustics*.
6. GREENWOOD, R.D., COWELL, J.R. (1992) "International Convention Centre Birmingham: structures and railway vibration isolation", *Proceedings of the Institution of Civil Engineers, Structures and Bridges*, 94 pp253-262.
7. SNOWDON, J.C. (1958) "The choice of resilient materials for anti-vibration mountings", *British Journal of Applied Physics*, 9.
8. NEWLAND, D. (1992) "Isolating of buildings from vibration", *Proceedings of the Second International Congress on recent developments in air and structureborne sound and vibration*.
9. ANDERSON, D.C. (1992) "Engineering prediction of railway vibration transmission in buildings", *Proceedings of the Institute of Acoustics*, 14 (4), pp73-80.